



## RECEIVING, CLEANING & OPERATING INSTRUCTIONS

### THANKYOU FOR PURCHASING THE POINT OF USE ASSEMBLY KIT

#### **RECEIVING**

Inspect the box for any evidence of shipping or handling damage. In case of shipping damage, claims should be filed promptly with the carrier.

#### **SPECIFICATION OF POU INDICATOR**

1. The POU assembly has been designed to fit on any Crystal Mountain floor standing water dispenser.
2. The operating pressure 45 PSI
3. Flow capacity > 1000 ml/min at 45 PSI.
4. Indicator function: Indicator will show working valve's failure or any leak from the tubing or fittings inside the reservoir. The bottom valve is designated as the primary valve with the top valve acting as the safety valve. The top valve terminates water flow there-by tripping and locking the indicator into the **RED** position.
5. Determine the cause of the failure before resetting the indicator switch to the **GREEN** position.

#### **INSTALLATION OF POU ASSEMBLY**

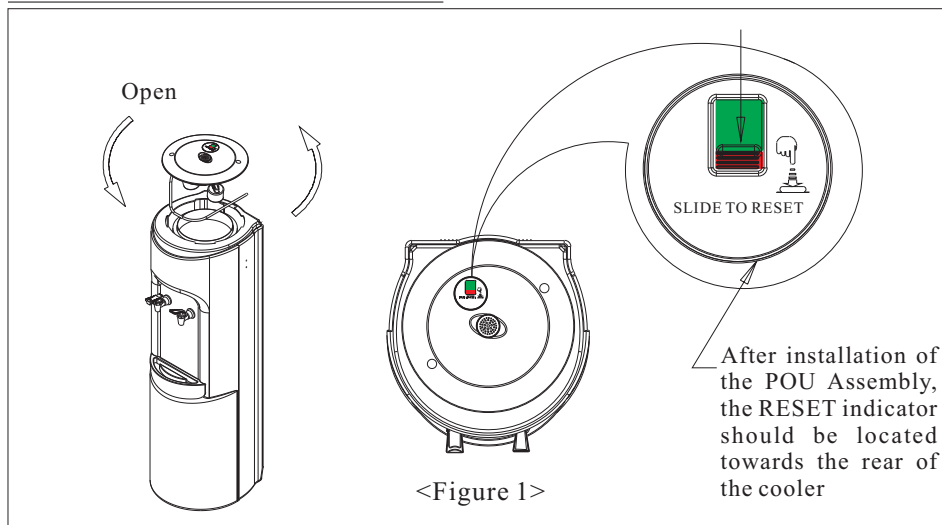

1. Remove POU Assembly from kit box – kit includes POU assembly, POU Cover, baffle disc and instructions.
2. Ensure that both floats are positioned downwards.
3. Remove the existing lid by turning counter clockwise and lifting off.
4. Install the POU assembly onto the cooler as per Figure 1. Position tubing so that it exits from the rear of the cooler as per Figure 2.

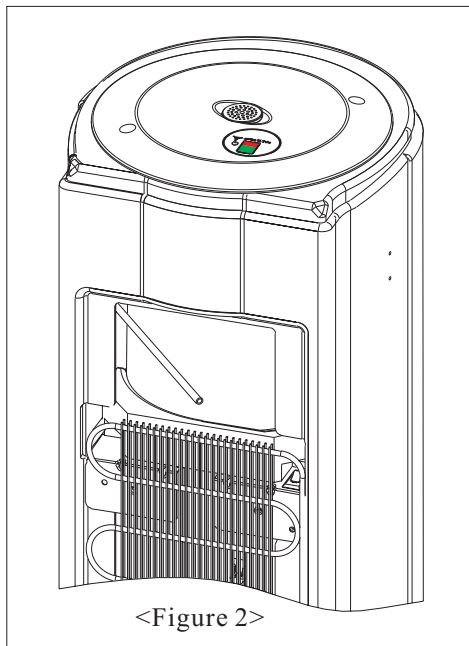

5. Customer to use an applicable 1/4" connector to be positioned between the POU tubing inlet and the water source.
  6. For those coolers with baffle cup (part # PLC-C000197C located on the underside of the cup), the baffle cup has to be replaced with Baffle disc (part # PLC-C000073) provided.
- NOTE: Plastic clips may be used to secure any excess 1/4" tubing to the top part of the condenser.

### **CHECK INDICATOR**

If indicator shows **RED**, slide the lever forward to reset the indicator back to **GREEN**. Ensure that indicator is in the **GREEN** position after installation is complete.

### **CLEANING**

Prior to installation and for periodic cleaning, rinse the POU Assembly with water and a mild dishwashing liquid detergent. **DO NOT USE** bleach or abrasive cleaners.

## STRUCTURE AND PARTS

See Figure 3

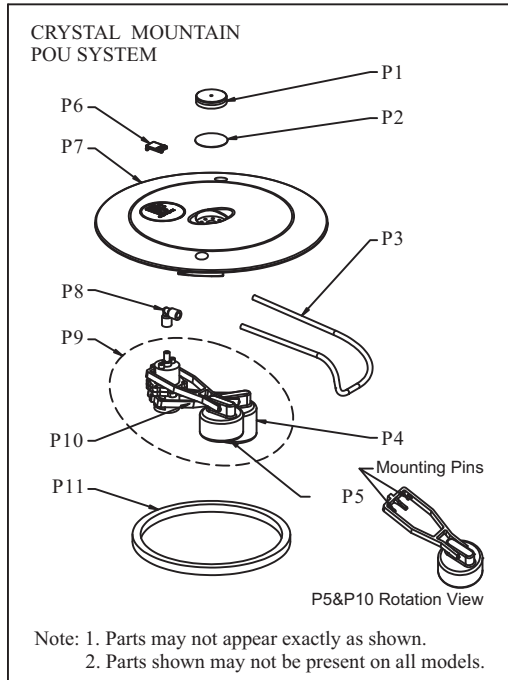

<Figure 3>

## PARTS LIST

NO.	DESCRIPTION	PART CODE
P	P1 INDICATOR ASSM - FILTER CAP	PLC-C100056
	P2 POU FILTER PAPER	MIS-C100049
	P3 1/4" TUBING FOR POU SYSTEMS	SIL-C000019
	P4 POU VALVE ASSM-FLOATER	PLC-C000150
	P5 POU VALVE ASSM-FLOATER - SHORT	PLC-C100195
	P6 INDICATOR ASSM - CLEAR WINDOW	SIL-C100010
	P7 INDICATOR ASSM-LID	PLC-C100057
	P8 1/4" POU PLASTIC ELBOWS	MIS-C000044
	P9 POU FLOAT ASSEMBLY	MIS-C000043
	P10 POU VALVE ASSEMBLY- ARM	PLC-C000149
	P11 GASKET, POU LID	SIL-C000026
<b>BOXED, POU ASSEMBLY (NO COVER)</b>		
	BOXED, POU ASSEMBLY (NO COVER)	SUB-C000216
<b>BOXED, POU COVER</b>		
A	GLACIER POU COVER - WHITE	SUB-C100108
B	GLACIER POU COVER - GRANITE	SUB-C100189
C	GLACIER POU COVER - BLACK	SUB-C100190
E	MOGUL POU COVER - WHITE	SUB-C100106
F	MOGUL POU COVER - GRANITE	SUB-C100192
G	SUMMIT POU COVER	SUB-C100158
<b>BOXED, POU ASSEMBLY + COVER</b>		
	BOXED, POU ASSEMBLY + WHITE GLACIER COVER	SUB-C100007
	BOXED, POU ASSEMBLY + GRANITE GLACIER COVER	SUB-C100084
	BOXED, POU ASSEMBLY + BLACK GLACIER COVER	SUB-C100175
	BOXED, POU ASSEMBLY + WHITE MOGUL COVER	SUB-C100092
	BOXED, POU ASSEMBLY + GRANITE MOGUL COVER	SUB-C100193
	BOXED, POU ASSEMBLY + SUMMIT COVER	SUB-C100133

# **CRYSTAL MOUNTAIN LIMITED WARRANTY**

Crystal Mountain warrants the POU Assembly Kit against defects and workmanship under normal use, when installed and operated in accordance with the installation instructions.

One (1) year from the date of sale, Crystal Mountain at their option will repair or replace any defective parts, during this period.

This warranty does not cover any damage due to accident, freight damage, misuse, abuse, and negligence; fouling of components due to liming, dirt, unsatisfactory water conditions or faulty plumbing. Crystal Mountain does not accept responsibility for personal injury resulting from misuse of equipment.

Unauthorized service work and finish deterioration due to normal use cannot be claimed under this warranty.

The customer acknowledges that water, like other liquids can cause damages to surfaces. Customer takes full responsibility for placing the cooler within a residence or business, and acknowledges that any failure to address drips, leaks, or spills is at the customers own risk.



## **Crystal Mountain Products Limited**

### **North American Sales Office**

11925 -145<sup>th</sup> Street  
Edmonton, Alberta  
Canada T5L 2H4  
Tel: 1 800 878 6422; 1 780 454 4545  
Fax: 1 780 454 9816  
Email: sales@crystalcoolers.com

### **European Sales Office**

Fence House, Fence Avenue  
Macclesfield, Cheshire  
United Kingdom SK10 1LT  
Tel: +44[0] 1625 439 111  
Fax: +44[0] 1625 502 527  
Email: cmeurope@crystalcoolers.com

## **Crystal Mountain International Limited**

Hong Kong Office  
Room 610  
Winfield Commercial Building 6-8a  
Prat Avenue, Tsimshatsui  
Kowloon, Hong Kong  
Tel: (852)2368 1989  
Fax: (852)3017 6727  
E-mail: cmasia@crystalcoolers.com